

# V51519W40WNZ1 Datasheet

1519 Series (L\* W\*H): 1.5\*1.9\*0.9mm

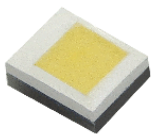

## Applications

- Automotive electronics
- Others applications

## Features

- Forward current:  $\leq 500\text{mA}$  ;
- Typical view angle 50% Iv:  $120^\circ$
- RoHS2.0 and REACH-compliant
- Glue color: White
- Emitting color: White
- ESD level 8kV(HBM)
- Reliability Test: AEC Q-102qualified

# V51519W40WNZ1

## Dimensional Drawing

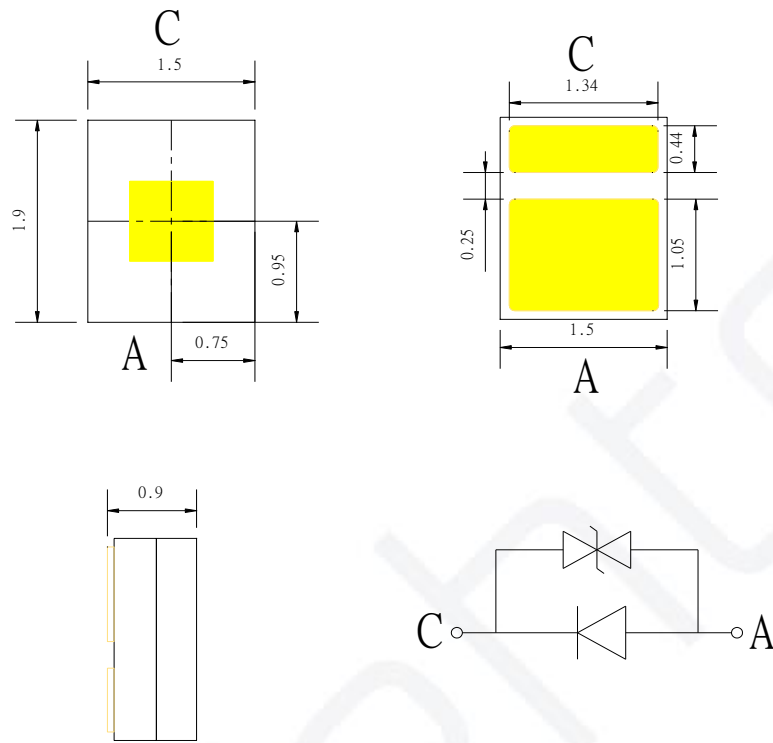

## Recommend Pad layout

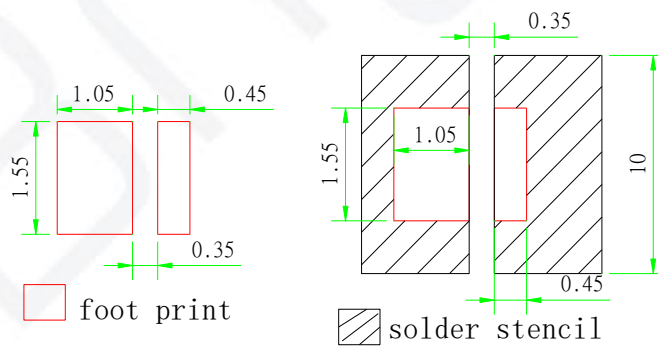

1. Dimensions are in millimeters.
2. General tolerance is  $\pm 0.1\text{mm}$ .

# V51519W40WNZ1

## Naming Rule

### V5-1519-W40-W-N-Z1

V5	1519	W40	W	N	Z1
Type	Package Size	Wavelength	Glue Color	Condition Code	Serial Number
V5: Automotive	1519: 1.5* 1.9mm	Wxx: white	W: No request	N: 350mA	Z: Zener 1: Serial number

## Maximum Ratings

T<sub>A</sub> : 25 °C

Parameter	Symbol		Values	Unit
Forward current	I <sub>F</sub>	max.	500	mA
Pulse forward current	I <sub>PF</sub>	max.	1000	mA
Power Dissipation	P <sub>D</sub>	max.	1800	mW
Reverse voltage	V <sub>R</sub>	max.	5	V
Junction temperature	T <sub>j</sub>	max.	150	°C
Operating temperature	T <sub>op</sub>	min.	-40	°C
		max.	125	
Storage temperature	T <sub>stg</sub>	min.	-40	°C
		max.	125	
Soldering temperature	T <sub>SD</sub>	max.	260	°C
Thermal Resistance Junction/ Solder Point	R <sub>THJ-S</sub>	max.	10	°C /W
Thermal Resistance Junction/Ambient Point	R <sub>THJ-A</sub>	max.	15	°C /W

1. There is no maximum or typical voltage parameter.
2. For other ambient, limited setting of current will be depended on de-rating curves.
3. Duty 1/10, pulse width 0.1ms.
4. The maximum of soldering time is 10 seconds in T<sub>SD</sub>.

# V51519W40WNZ1

## Characteristics

IF : 350mA | TA : 25 °C

Parameter	Symbol		Values	Unit
Color Coordinate	Cx/Cy		0.323	
			0.340	
View angle	$2\theta_{1/2}$	typ.	120	°
		min.	100	
Luminous Flux	$\Phi_V$	typ.	120	lm
		max.	150	
Forward voltage	$V_F$	min.	2.8	
		typ.	3.2	V
		max.	3.6	
Reverse current ( $V_R=5V$ )	$I_R$	max.	10	$\mu A$

1. Tolerance of Measure:

Forward Voltage:  $\pm 0.1V$ , Luminous Intensity:  $\pm 10\%mcd$ , Dominant Wavelength:  $\pm 1.0nm$ , Color Coordinate  $\pm 0.005$

# V51519W40WNZ1

## Bin groups

### 1. Luminous Flux (IF=350mA)

Group		Values	Unit
26	min.	100	lm
	max.	115	
27	min.	115	
	max.	130	
28	min.	130	
	max.	150	

### 2. Forward Voltage (IF=350mA)

Group		Values	Unit
K	min.	2.8	V
	max.	3.0	
L	min.	3.0	
	max.	3.2	
M	min.	3.2	
	max.	3.4	
N	min.	3.4	
	max.	3.6	

# V51519W40WNZ1

## 3. Chromaticity Coordinate Groups

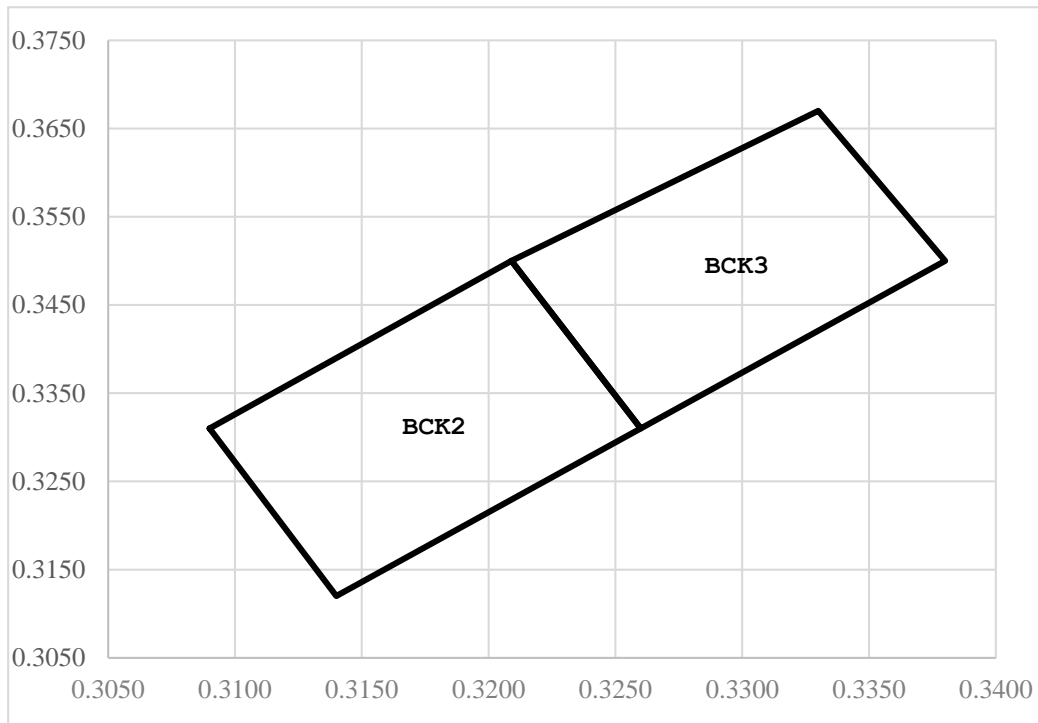

Group								
BIN	x	y	x	y	x	y	x	y
BCK2	0.3090	0.3310	0.3140	0.3120	0.3260	0.3310	0.3209	0.3500
BCK3	0.3209	0.3500	0.3260	0.3310	0.3380	0.3500	0.3330	0.3670

# V51519W40WNZ1

## Typical Electrical Optical Characteristics Curves

Radiation Characteristics

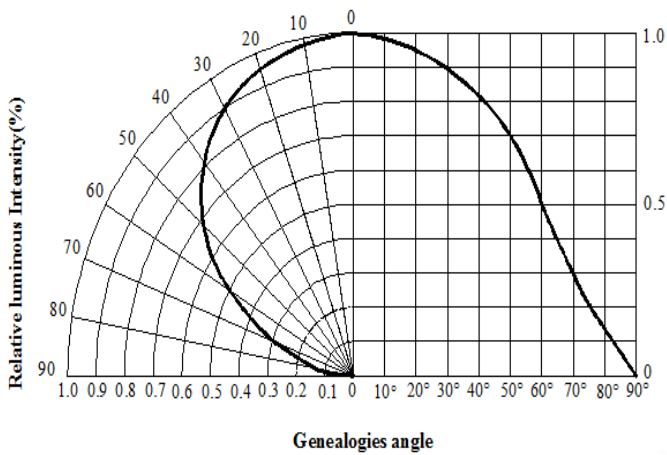

Relative Spectral Power Distribution

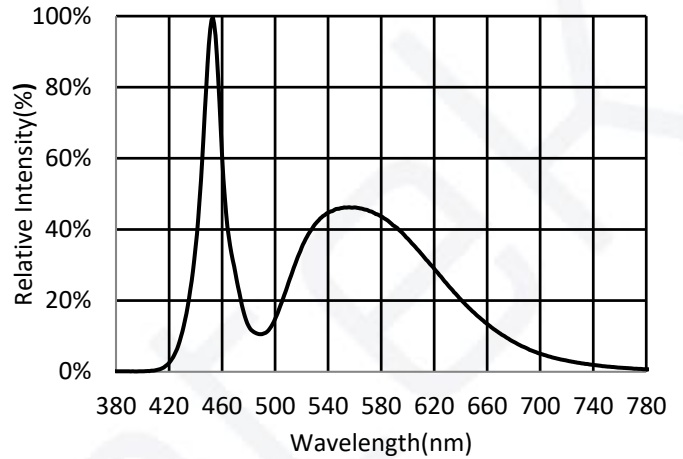

Relative Luminous Flux Vs Forward Current

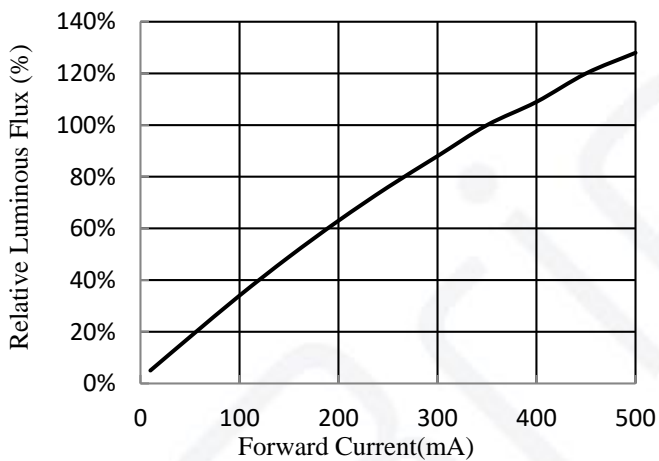

Relative Luminous Flux Vs Solder Temperature

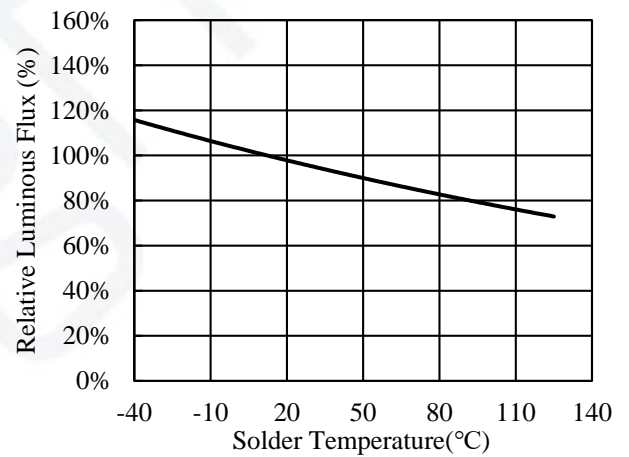

Forward Current Vs Forward Voltage

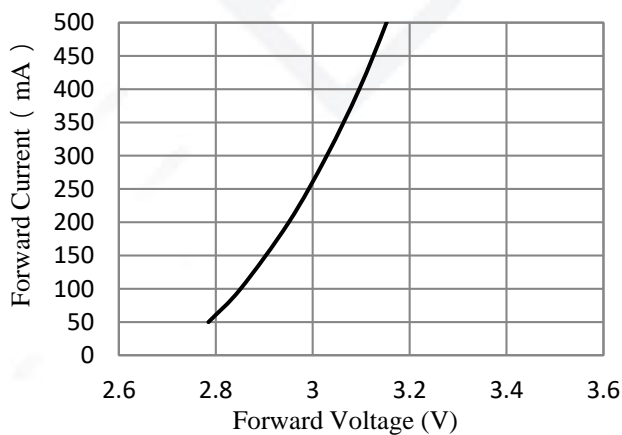

Forward Voltage Vs Solder Temperature

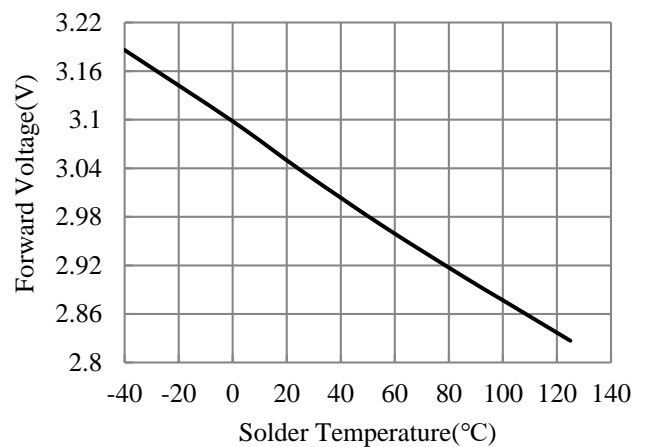

# V51519W40WNZ1

### Chromaticity Coordinate vs Forward Current

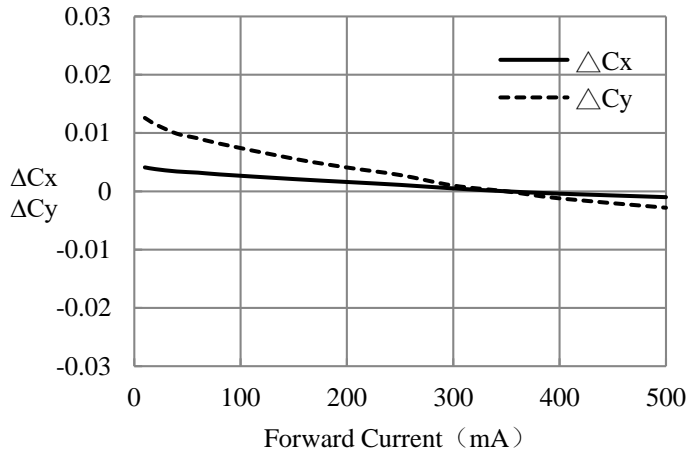

### Chromaticity Coordinate vs Solder Temperature

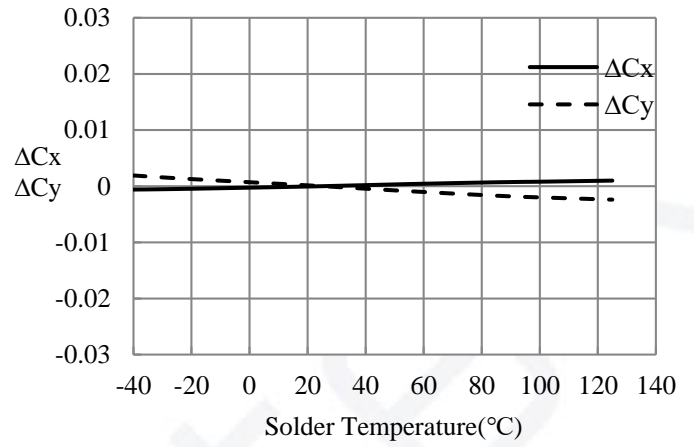

### Thermal Design for De-rating

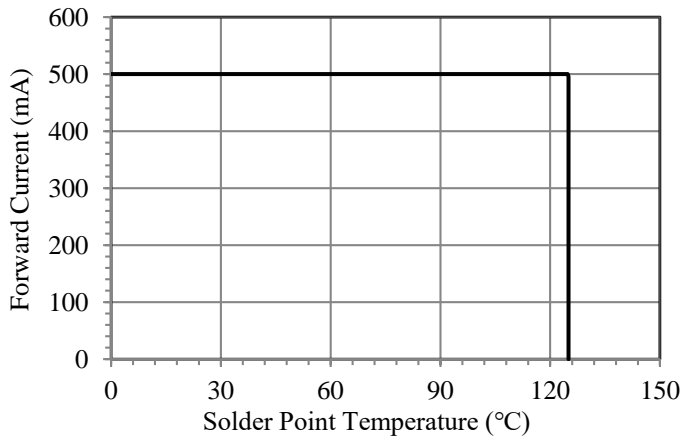



## Reflow Soldering Profile

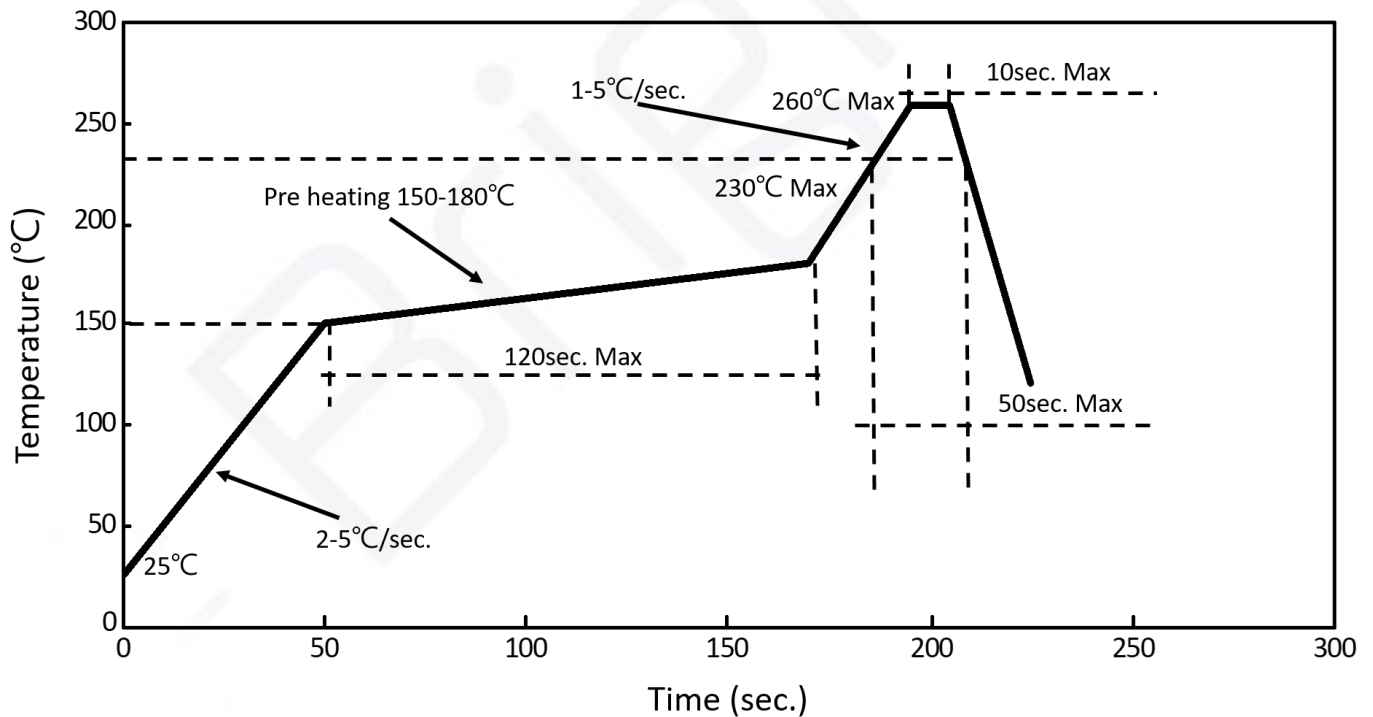

1. We recommend the reflow temperature 240°C ( $\pm 5^\circ\text{C}$ ).the maximum soldering temperature should be limited to 260°C.
2. Do not stress the silicone resin while it is exposed to high temperature.
3. The reflow process should not exceed 3 times.

Brightek

## Test Circuit and Handling Precautions

### 1. Test circuit

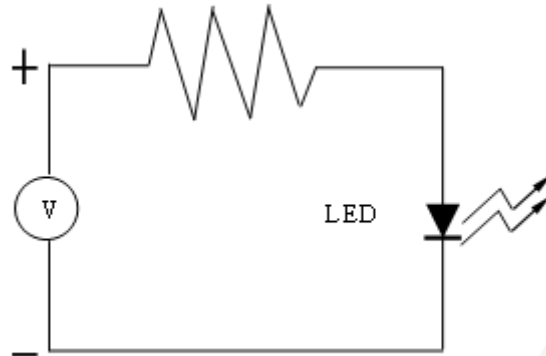

### 2. Handling precautions

#### 2.1 Over-current-proof

Customer must apply resistors for protection; otherwise slight voltage shift will cause big current change (Burn out will happen).

#### 2.2 Storage

① It is recommended to store the products in the following conditions:

- Humidity: 60% R.H. Max.
- Temperature :  $5^{\circ}\text{C} \sim 30^{\circ}\text{C}$  ( $41^{\circ}\text{F} \sim 86^{\circ}\text{F}$ )

② Shelf life in sealed bag: 12 month at  $< 5^{\circ}\text{C} \sim 30^{\circ}\text{C}$  and  $< 60\%$  R.H. after the package is Opened, the products should be used within 1 weeks or they should be keeping to storage at  $\leq 20\%$  R.H. with zip-lock sealed.

#### 2.3 Baking

Suggest packing open after 1 weeks, before use baking products, conditions as follows:

- ①  $60 \pm 3^{\circ}\text{C}$  X 6hrs and  $< 5\%$  RH, for reel
- ②  $125 \pm 3^{\circ}\text{C}$  X 2hrs, for single LED

It shall be normal to see slight color fading of carrier (light yellow) after baking in process.

# V51519W40WNZ1

## Tapping

### 1. Dimensions of Tape (Unit: mm)

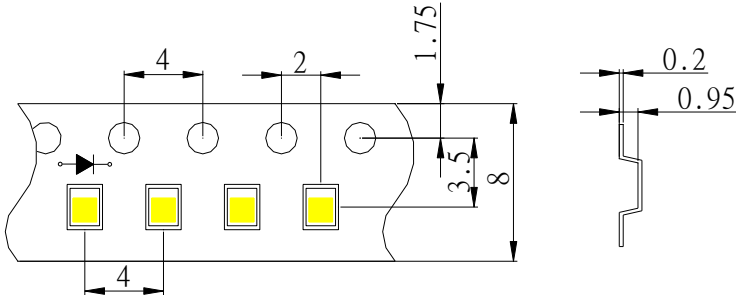

### 2. Arrangement of Tape

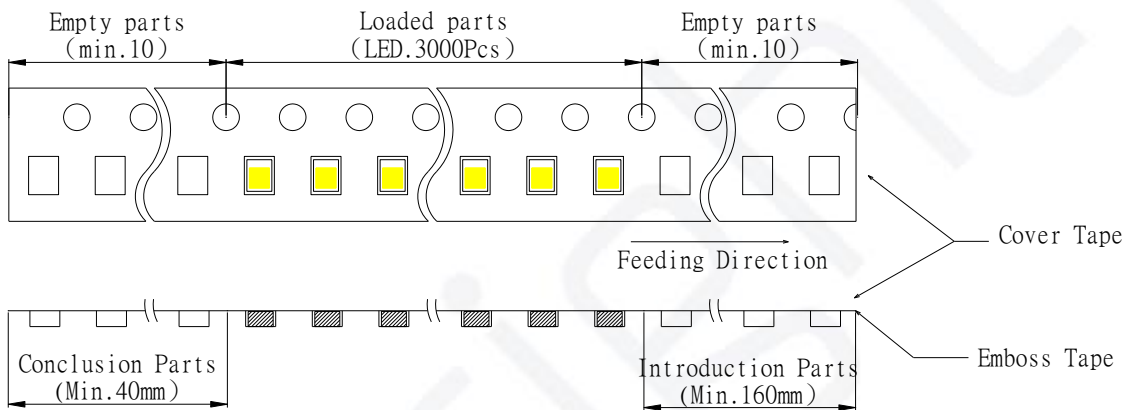

### 3. Dimensions of Reel (Unit: mm)

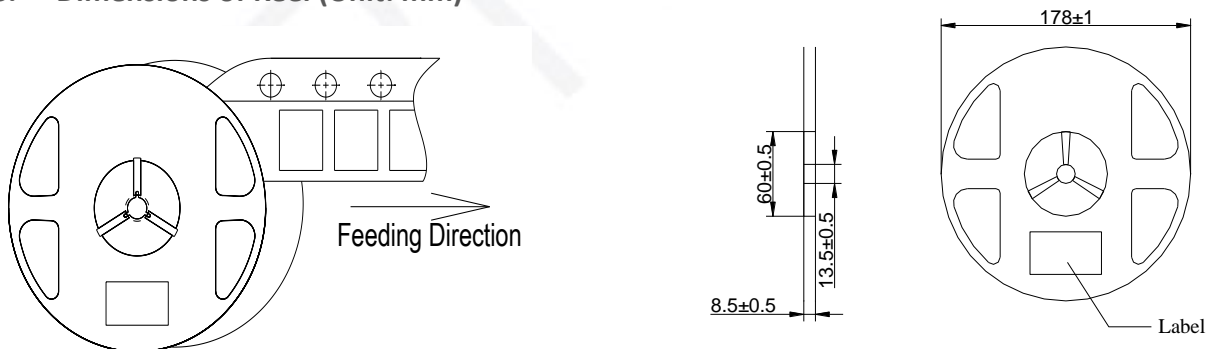

### Notes:

1. Empty component pockets are sealed with top cover tape
2. The max loss number of SMD is 2pcs
3. The cathode is oriented towards the tape sprocket hole in accordance with ANSI/EIA RS-481 specifications
4. 2,000pcs per reel
5. The remainder packing in multiples of 500pcs.

# V51519W40WNZ1

## Packing

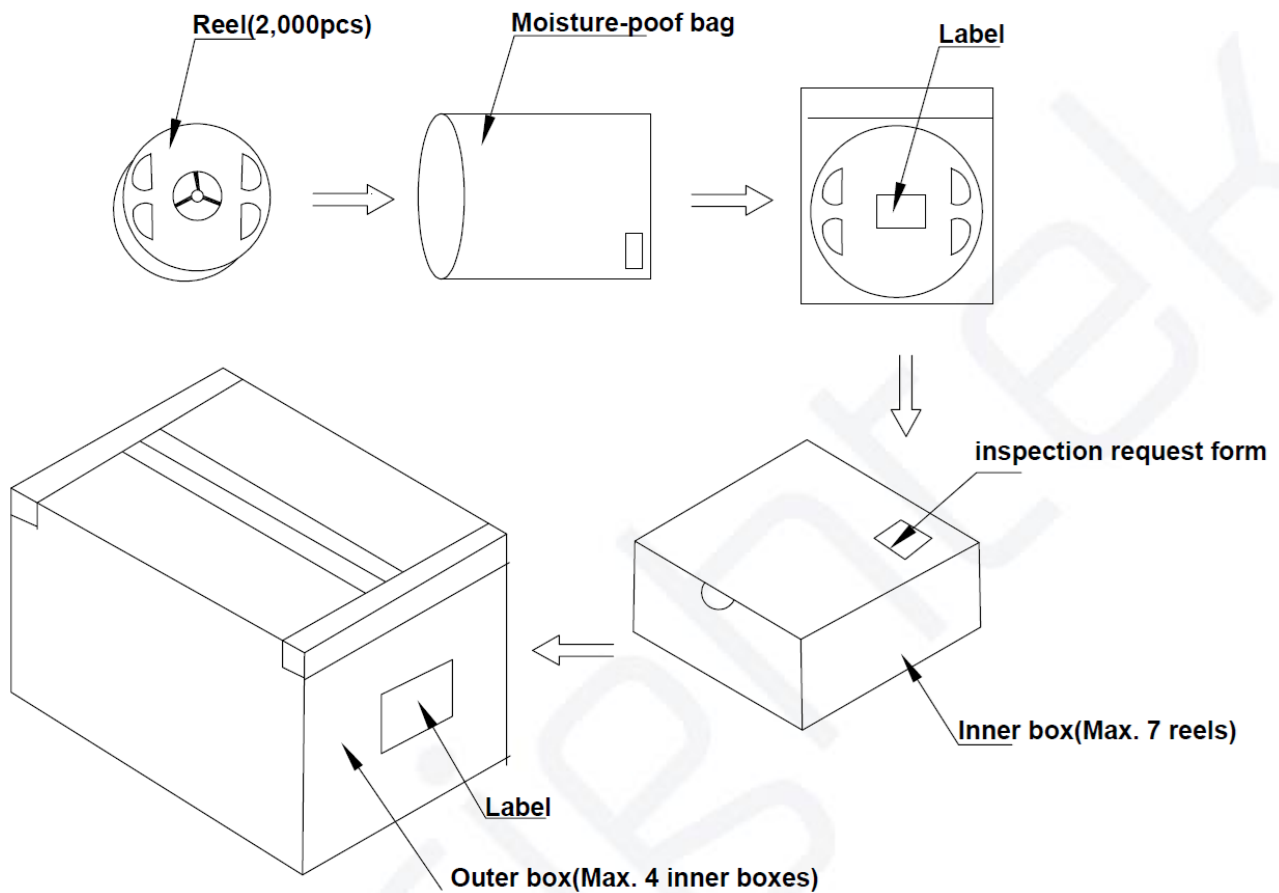

Reeled product (max.2,000 ) is packed in a sealed moisture-proof bag. Seven bags are packed in an inner box (size: about 260 X 230 X 100 mm) and four inner boxes are in an outer box (size: about 480 X 275 X 215 mm). On the label of moisture-pooof bag, there should be the information of Part No., Lot No. and quantity number; also the total quantity number should be on inspection request form on outer box.